

Case IH Series Riser Kit

Assembly Instructions

PARTS LIST

Please order replacement parts by PART NO. and DESCRIPTION.

REF.#	PART #	QTY.	DESCRIPTION
1.	R3E000055S0	1	Case IH Riser-Front
2.	R3E000056S0	1	Case IH Riser-Rear
3.	R3E000057S0	1	Case IH Riser-Left
4.	R3E000058S0	1	Case IH Riser-Right
5.	R3E000059S0	4	Case IH Riser Corner Tie
6.	R3E000065S0	1	Riser Rubber Seal
7.	1AFC37E00L0	24	5/16" x 3/4" Serrated Flange Bolt
8.	1AFC08E0000	24	5/16" Serrated Flange Nut

STEP 1:

Fasten both the front and rear Riser Boards to the top lip of the grain tank using three 5/16" x 3/4" serrated flange bolts and three 5/16" serrated flange nuts per board. (Boards may need to be adjusted once the left & right boards have been attached to square the unit.)

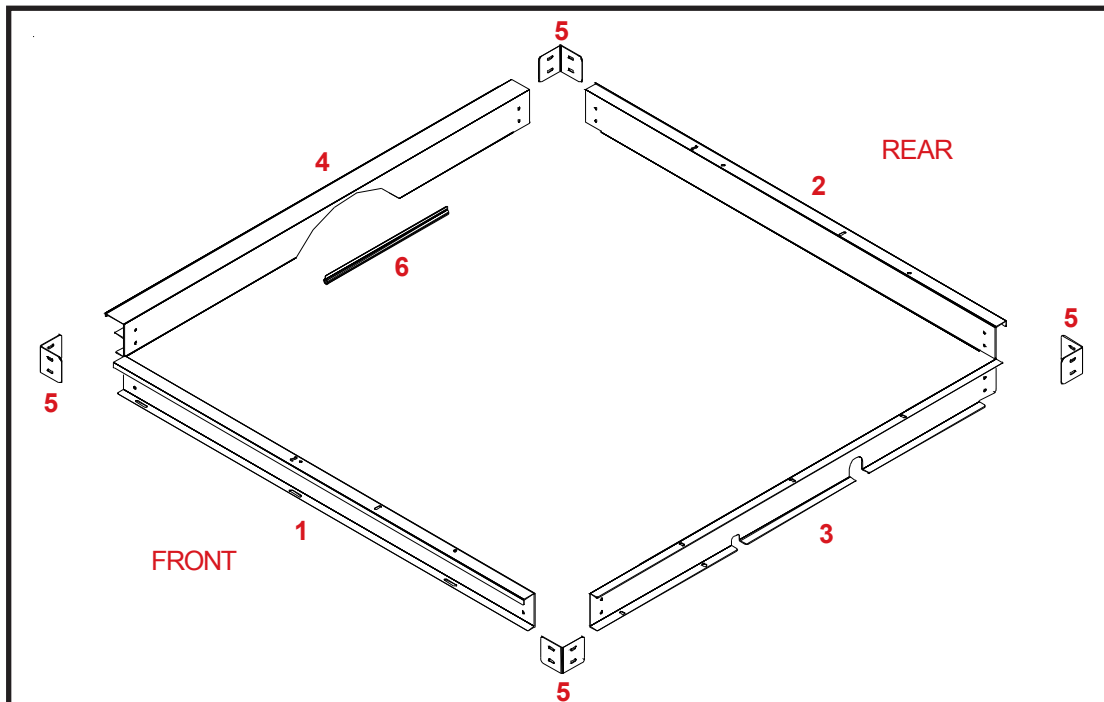

Figure 1

STEP 2:

Attach the supplied rubber seal to the right Riser board by slipping the metal clip end of the seal over the half moon cut. (Seal may need to be adjusted to create a tight fit once assembled to combine.) See figure 2.

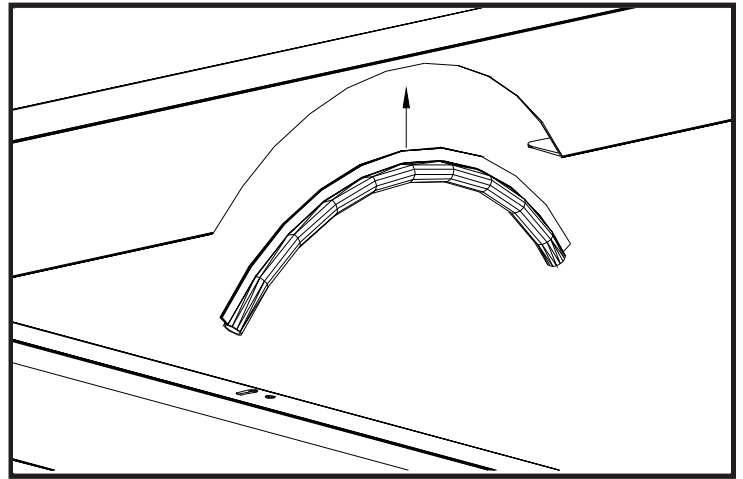

Figure 2

STEP 3:

Assemble the right and left Riser boards to the front and rear Riser boards attached to the top of the grain tank. Butt the right and left Riser boards against the front and rear boards and secure together using the formed Riser tie bracket. Fasten the brackets to the outside of the boards using four 5/16" x 3/4" serrated flange bolts and four 5/16" serrated flange nuts per bracket. See figure 3 & 4A.

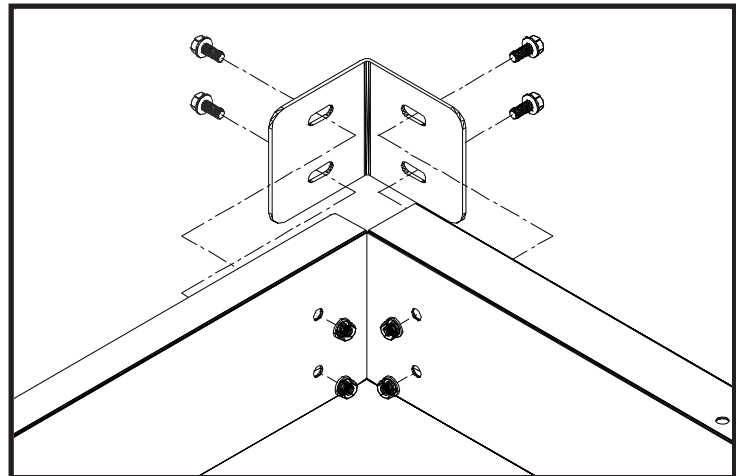

Figure 3

STEP 4:

Once the corner tie brackets have been secured to the Riser boards, square the unit with the grain tank before tightening down the front and rear boards to the top of the grain tank.

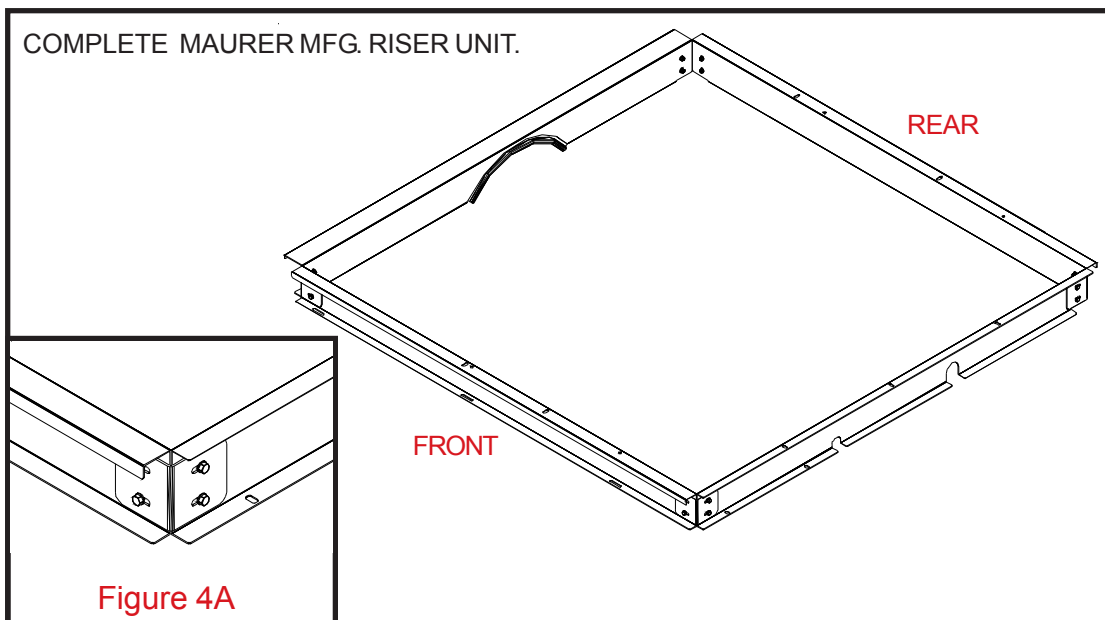

Figure 4

If you have questions not answered in this instruction sheet, require additional copies, or if your instruction sheet is damaged, please contact your dealer or Maurer Manufacturing, P.O. Box 160, 1300 38th Ave. West, Spencer, Iowa 51301, Ph: (712) 262-2992 Fax: (712) 262-1022 www.maurermfg.com