



# John Deere Tank Brace Kit

## JOHN DEERE 9000 SERIES COMBINES

### INSTALLATION INSTRUCTIONS

REF. NO.	PART NO.	QTY.	DESCRIPTION
1.	R3E000046P0	1	Left Tank Brace
2.	R3E000047P0	1	Right Tank Brace
3.	1AFC35FAA00	3	5/16" x 1" Self Tapping Screw

#### **STEP 1:**

Install the right tank brace to the vertical support located on the inside of the rear tank wall using three 5/16" self tapping screws. See figure 1.

#### **STEP 2:**

Remove existing bolts from the left rear outside corner of the tank, align brace with holes (be sure brace is resting on angle below) and fasten with original bolts. See figure 2.

**NOTE:** Failure to use bracing can result in damage to tank.

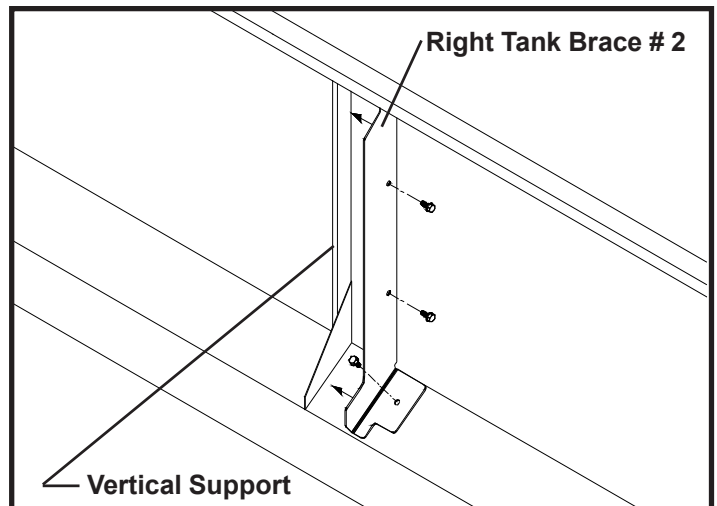

Figure 1

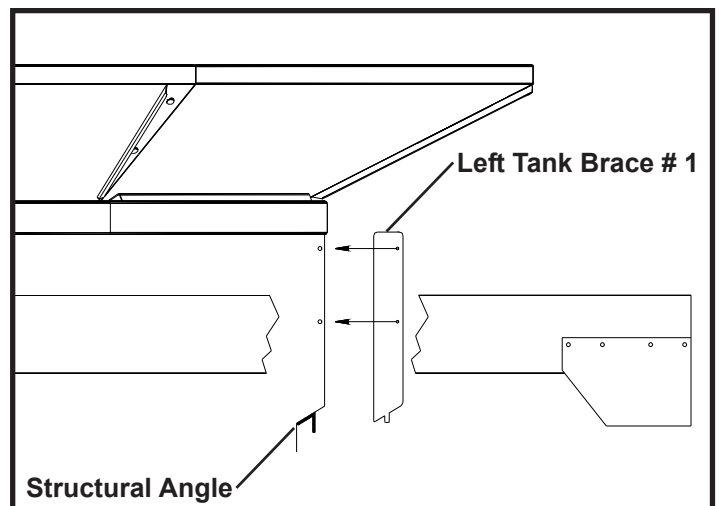

Figure 2