

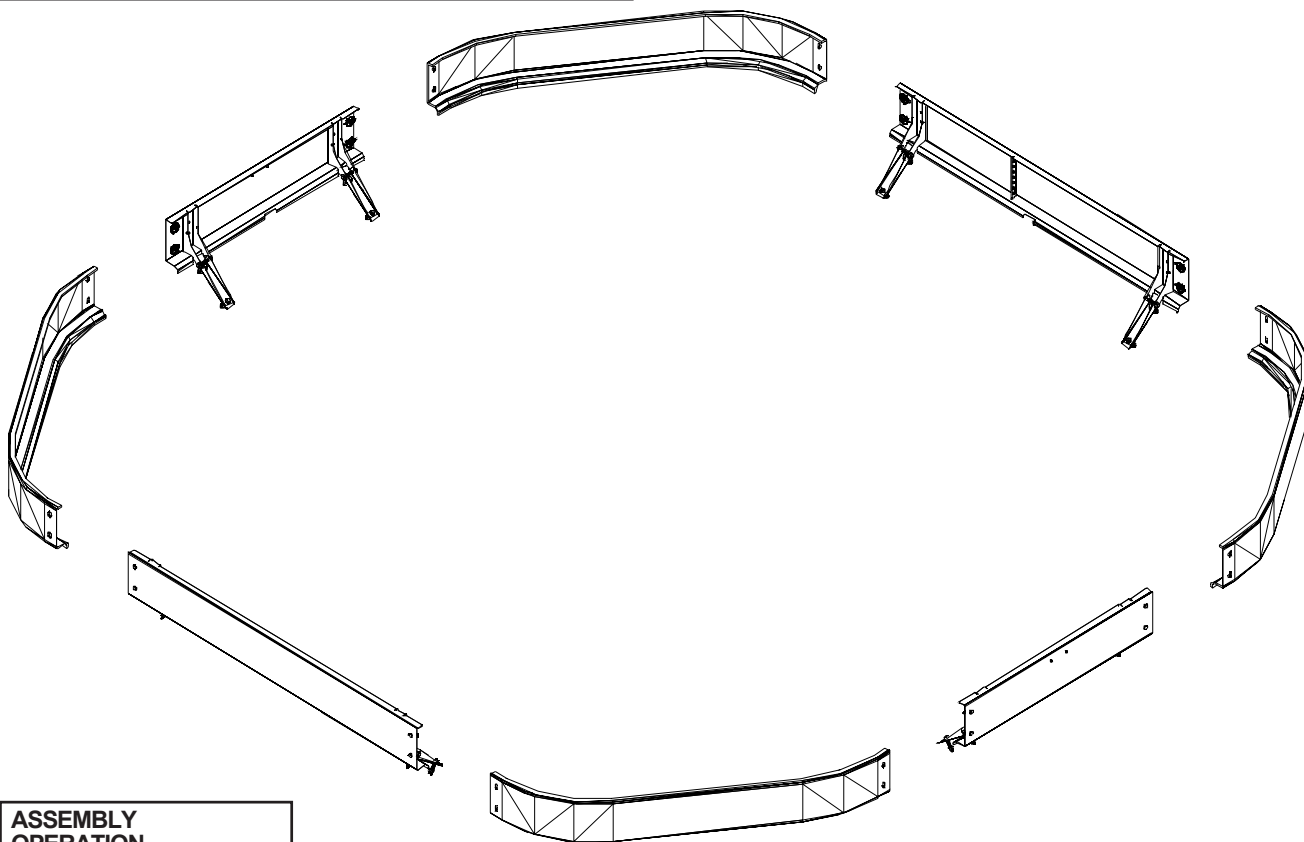

Combine Grain Tank Extension Tip-Up Kit M-60

**FITS JOHN DEERE 60 & 70 SERIES STS COMBINES
OPERATORS / ASSEMBLY MANUAL**

**PLACE IN COMBINE CAB AFTER ASSEMBLY
FOR FUTURE REFERENCE.**



**ASSEMBLY
OPERATION
REPLACEMENT PARTS**

INTRODUCTION

Thank you for purchasing a Maurer grain tank extension Tip-Up kit. Proper care and use will result in many years of service.



WARNING: TO AVOID PERSONAL INJURY OR DEATH, OBSERVE THE FOLLOWING INSTRUCTIONS:

Ensure that anyone present is clear before applying power to any machinery used in conjunction with a Maurer grain tank extension.

Never allow anyone in or near the grain tank of a combine during loading or unloading of grain. The accumulation of grain is dangerous and can cause entrapment, resulting in serious injury or death by suffocation.

Do not exceed advertised maximum capacity of a Maurer grain tank extension.

GENERAL INFORMATION

1. Read assembly instructions carefully. Study assembly procedures and all illustrations before you begin assembly. Note which parts are used in each step. This unit must be assembled in proper sequence or complications will result.
2. When placing a parts order, refer to this manual for proper part numbers and place order by **PART NO. and DESCRIPTION.**
3. Whenever terms "**LEFT**" and "**RIGHT**" are used in this manual it means from a position behind combine and facing forward.

Table of Contents

General information	2
Safety, Signal Words	3
Product Safety Guidelines	4
Product Disclaimer	4
Safety Sign Locations	5
Safety Sign Care	5
Parts Breakdown	6-7
Assembly Instructions	7-8
Tank Full Sensor	8
GPS Bracket	8

SAFETY

TAKE NOTE! THIS SAFETY ALERT SYMBOL FOUND THROUGHOUT THIS MANUAL IS USED TO CALL YOUR ATTENTION TO INSTRUCTIONS INVOLVING YOUR PERSONAL SAFETY AND SAFETY OF OTHERS. FAILURE TO FOLLOW THESE INSTRUCTIONS CAN RESULT IN INJURY OR DEATH!



**THIS SYMBOL MEANS
ATTENTION
BECOME ALERT
YOUR SAFETY IS INVOLVED!**

SIGNAL WORDS

Note use of following signal words **DANGER**, **WARNING**, and **CAUTION** with safety messages. The appropriate signal word for each has been selected using the following guidelines:

DANGER: Indicates an imminently hazardous situation that, if not avoided, will result in death or serious injury. This signal word is to be limited to most extreme situations typically for machine components which, for functional purposes, cannot be guarded.

WARNING: Indicates a potentially hazardous situation that, if not avoided, could result in death or serious injury, and includes hazards that are exposed when guards are removed. It may also be used to alert against unsafe practices.

CAUTION: Indicates a potentially hazardous situation that, if not avoided, may result in minor or moderate injury. It may also be used to alert against unsafe practices.

If you have questions not answered in this manual, require additional copies, or if your manual is damaged, please contact your dealer or Maurer Manufacturing, P.O. Box 160, 1300 38th Ave. West, Spencer, Iowa 51301, Ph: (712) 262-2992 Fax: (712) 262-1022 www.maurermfg.com



PRODUCT SAFETY GUIDELINES

Every year many accidents occur which could have been avoided by a few seconds of thought and a more careful approach to handling equipment. You, the operator, can avoid many accidents by observing the following precautions in this section. To avoid personal injury, study the following precautions and insist those working with you, or you yourself, follow them.

Replace any caution, warning, danger or instruction safety decal that is not readable or is missing. Location of such decals is indicated in this booklet.

Review safety instructions with all users annually.

Operator should be a responsible adult. **DO NOT ALLOW PERSONS TO OPERATE OR ASSEMBLE THIS UNIT UNTIL THEY HAVE DEVELOPED A THOROUGH UNDERSTANDING OF SAFETY PRECAUTIONS AND HOW IT WORKS.**

Do not paint over, remove, or deface any safety signs or warning decals on your equipment. Observe all safety signs and practice instructions on them.

Never exceed limits of a piece of machinery. If it's ability to do a job, or to do so safely is in question **DON'T TRY IT.**

Fold and secure (if needed) the grain tank extension panels when transporting the combine to avoid contact with low power lines and other obstructions.

Ensure that any additional bracing and safety equipment have been installed according to this manual. (Some models do not require additional bracing or safety equipment)

Never exceed the maximum advertised capacity of the grain tank extension. By doing so you risk damage to the grain tank extension and combine.

PRODUCT DISCLAIMER

Increasing the grain tank capacity of any combine by use of this product is at the discretion of the owner. Increasing the grain holding capacity of any combine may affect the structural aspects of the combine as well as drive line components and tires. Although Maurer Mfg. has included additional support bracing on selected models, it does not assume liabilities, or make any warranties pertaining to the structural stability or performance of any combine. See the combine owners/operators manual for additional combine specifications and safety information not listed in this manual.



SAFETY SIGN LOCATIONS

Types of safety sign and locations on equipment are shown in illustration below. Good safety requires that you familiarize yourself with various safety signs, type of warning, and area or particular function related to that area, that requires your SAFETY AWARENESS.

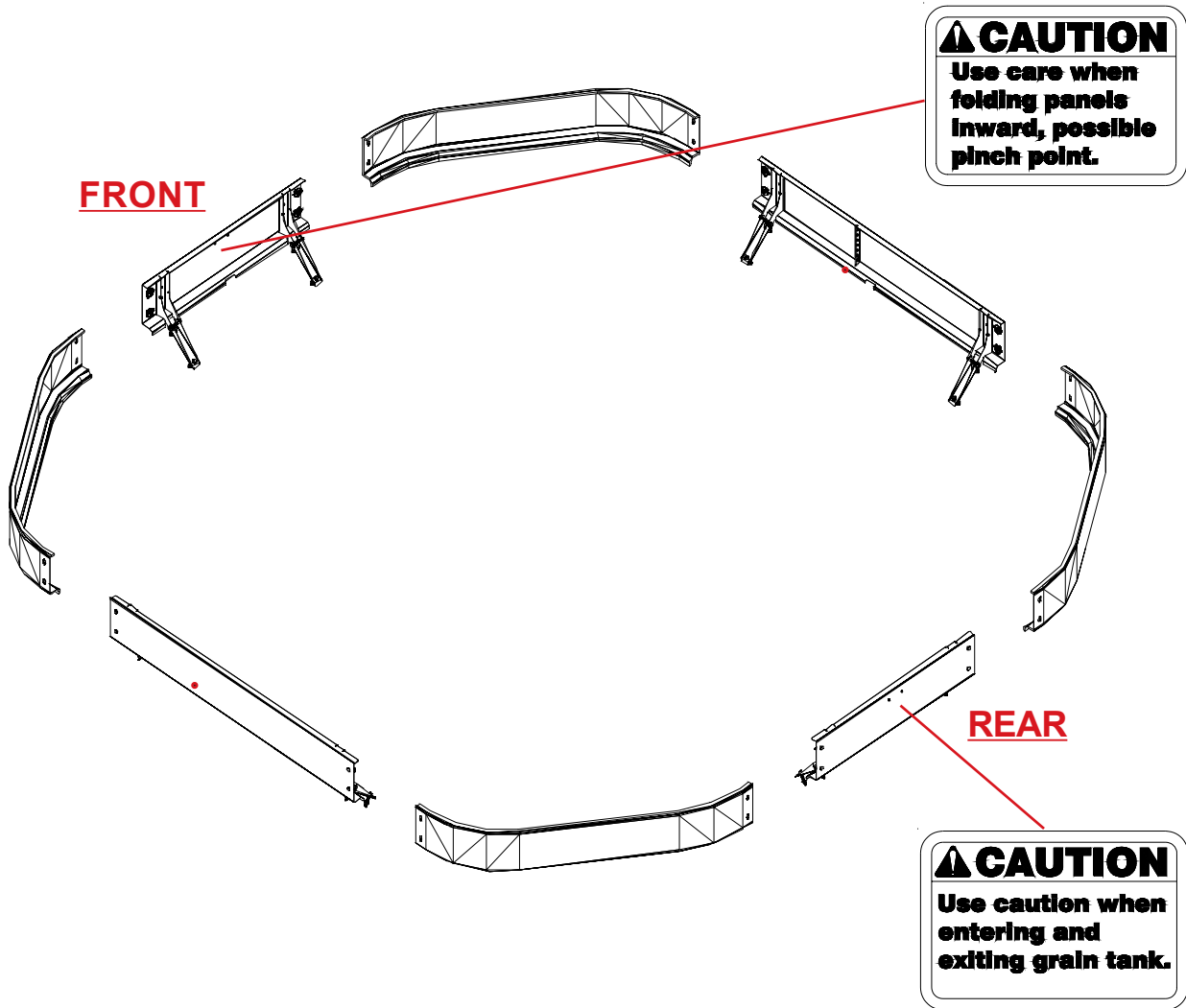

SAFETY SIGN CARE

- Keep safety signs clean and legible at all times.
- Replace safety signs that are missing or have become illegible.
- Replacement parts that displayed a safety sign should also display current sign.
- Safety signs are available from the Spencer plant.

Tip-Up Kit Parts Breakdown

M60 Tip-Up Kit for John Deere STS 60 Series

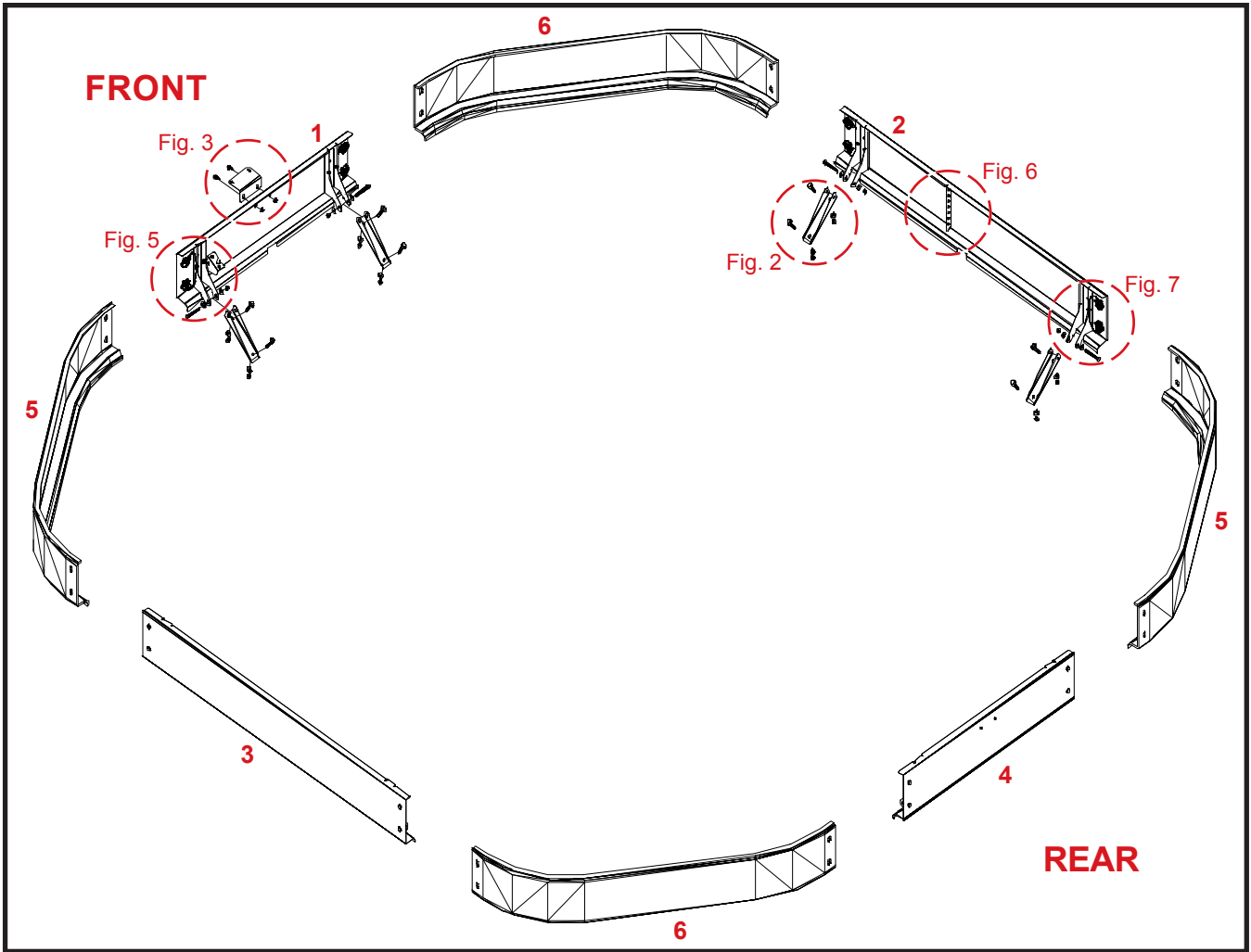

Figure 1

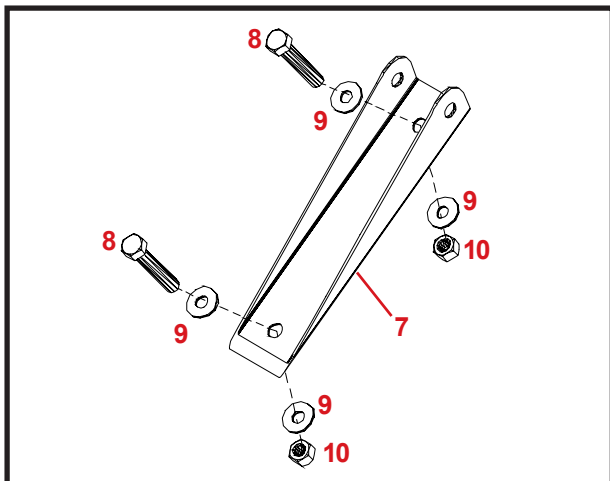

Figure 2

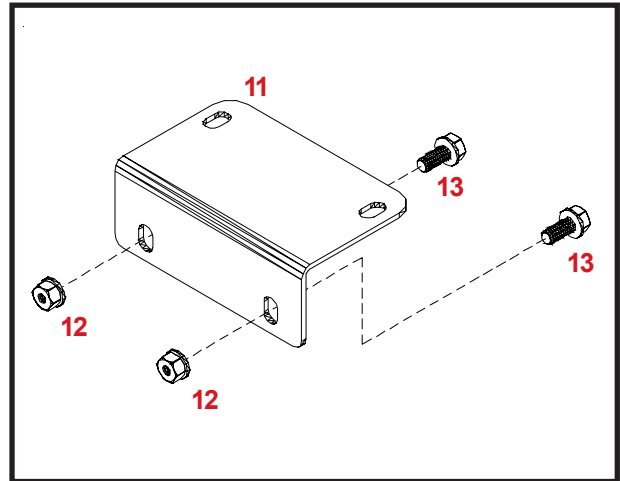

Figure 3

PARTS LIST

Please order replacement parts by **PART NO.** and **DESCRIPTION.**

REF. NO.	PART NO.	QTY.	DESCRIPTION
1.	R5E000056PO	1	Front Tip-Up Panel Assy. JD M60
2.	R5E000057PO	1	Right Tip-Up Panel Assy. JD M60
3.	R5E000058PO	1	Left Tip-Up Panel Assy. JD M60
4.	R5E000059PO	1	Rear Tip-Up Panel Assy. JD M60
5.	1AR00000017	2	Left Front & Right Rear Plastic Corner Panel
6.	1AR00000018	2	Right Front & Left Rear Plastic Corner Panel
7.	R3E000114PO	8	Bottom Hinge - M60 Tip-Up
8.	1AFC12FBAD0	16	3/8" x 2-1/4" Hex Bolt
9.	1AF009E0000	48	5/16" Flat Washer
10.	1AFC18F0000	24	3/8" Nylon Lock Nut
11.	R3E000023P0	1	GPS Bracket - JD Large
12.	1AFC08E0000	2	5/16" Flange Nut
13.	1AFC37E00L0	2	5/16" x 3/4" Flange Bolt
14.	1AFC05D0000	2	1/4" Center Lock Nut
15.	1AF009D0000	2	1/4" Flat Washer
16.	1AFC12DAA05	2	1/4" x 1" Hex Bolt
17.	R3E000003PO	1	Base Light Bracket
18.	1AFC12FCA05	8	3/8" x 3" Hex Bolt
19.	1AF034CAAI0	16	3/16" x 1-9/16" Lynch Pin
20.	1AF032D0000	8	Plastic Press Rivot for Lanyards
21.	1AF031DKA00	16	Nylon Lanyard
*22.	1AEX0015240	1	M60 Sensor Wire Harness

* Indicates items not shown in illustrations

ASSEMBLY INSTRUCTIONS

STEP 1:

The full bin sensor and bin light will need to be removed from the factory extension before any Tip-Up panels can be assembled to the factory extension.

STEP 2:

Use the existing holes in the outer ribs of the Factory JD Extension Panels as reference points. Use a 7/16" dia bit and electric drill, to drill holes completely through the panels as shown in figure 4.

NOTE: Some of the Factory JD Extension panels have a third rib located in the center of the panels. DO NOT DRILL OUT EXISTING HOLES ON CENTER RIBS FOR HINGES!!

STEP 3:

Fasten the bottom Tip-Up hinge to the Factory JD Extension panels using the 3/8" x 2-1/4" hex bolts, 5/16" flat washers, and 3/8" nylon lock nuts as shown in figure 2 on previous page.

NOTE: All steel Tip-Up panels must be installed first to ensure proper fit.

NOTE: DO NOT over tighten nuts and distort hinge component, but ensure nylon lock nut fully engages bolt threads.

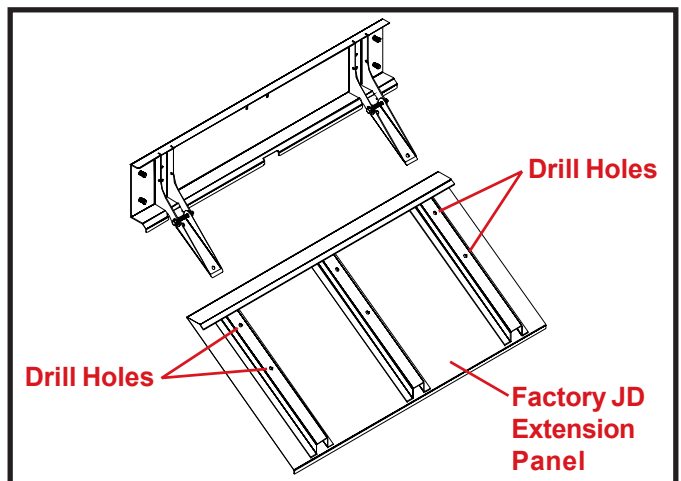

Figure 4



ATTENTION: During assembly ensure the following safety decals are located correctly. See illustration on page 5.



Located on outside of rear panel.



Located on inside of front panel.

STEP 4:

Fasten the steel Tip-Up panels to the bottom hinges using the 3/8" x 3" hex bolts, 5/16" flat washers, and 3/8" nylon lock nuts. See figure 5.

STEP 5:

Once the front, rear, and side panels have been secured to the extension, fold the panels outward. Insert the four plastic corner panel to mate with the inside of the four steel panels. Fasten the joints with one 3/16" lynch pin per clevis pin. See figure 7.

STEP 6:

Align one nylon lanyard with one press rivet and fasten together. Loop and lock the end of the lanyard around the ring of the lynch pin and proceed to pin the panel joint together. See figure 7.

TANK FULL BIN SENSOR

Mount the tank full bin sensor to the desired height on the right Tip-Up panel. Use one 1/4" x 1" hex bolt, one 1/4" flat washer, and one 1/4" center lock nut. See figure 6.

LIGHT BRACKET & LIGHT

Mount the light bracket on the left hinge of the front Tip-Up panel. Use one 1/4"x 1" hex bolt, one 1/4" flat washer, and one 1/4" center lock nut. See figure 5. Mount OEM light on bracket using original hardware.

GPS BRACKET

Remove the partial cut slugs from the front panel and fasten the provided GPS bracket to the outside of the panel using two 5/16" x 3/4" serrated flange bolts and two serrated flange nuts. See figure 1 & 3 on page 6.

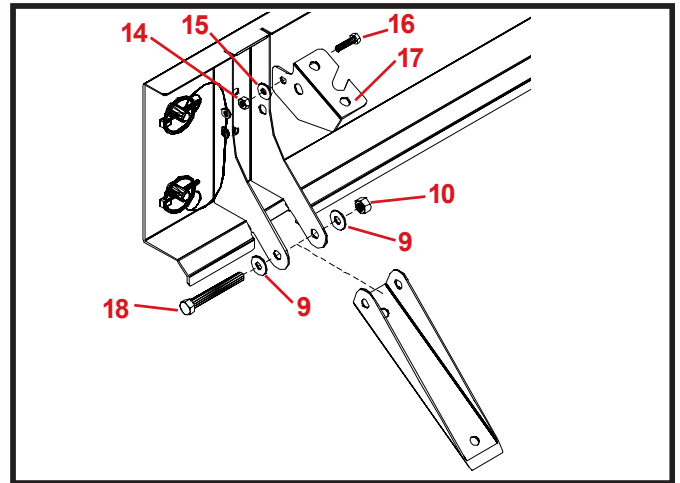

Figure 5

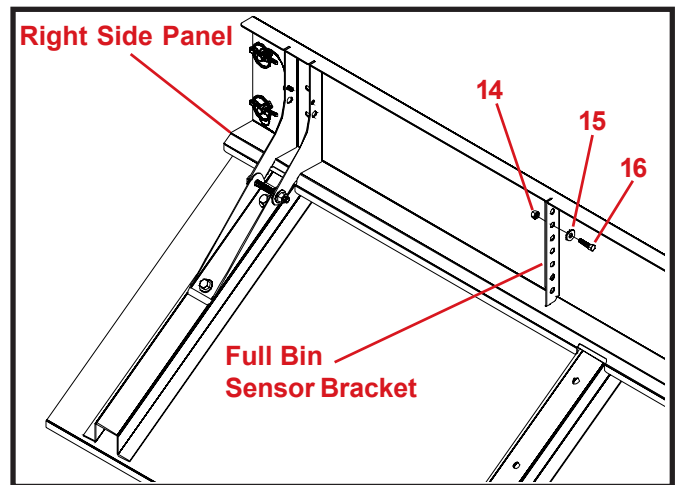

Figure 6

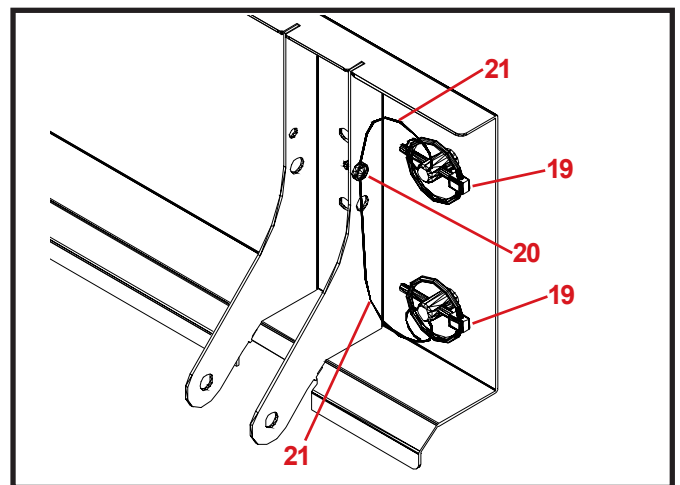

Figure 7